

지시의 용량계수		지시의 일반계수 사용치 (KSB ISO 2768-1)										표면 거칠기 (KSB 0161, 0507, 0617)									
구분	치수	0.5	6	30	120	400	1000	2000	Ra	0.1	0.2	0.4	0.8	1.6	3.2	6.3	12.5	25	50	100	
정밀	정밀	±0.1	±0.2	±0.3	±0.5	±0.8	±1.2	±2.0	▽	▽	▽	▽	▽	▽	▽	▽	▽	▽	▽	▽	
일반	일반	±0.1	±0.2	±0.3	±0.5	±0.8	±1.2	±2.0	▽	▽	▽	▽	▽	▽	▽	▽	▽	▽	▽	▽	

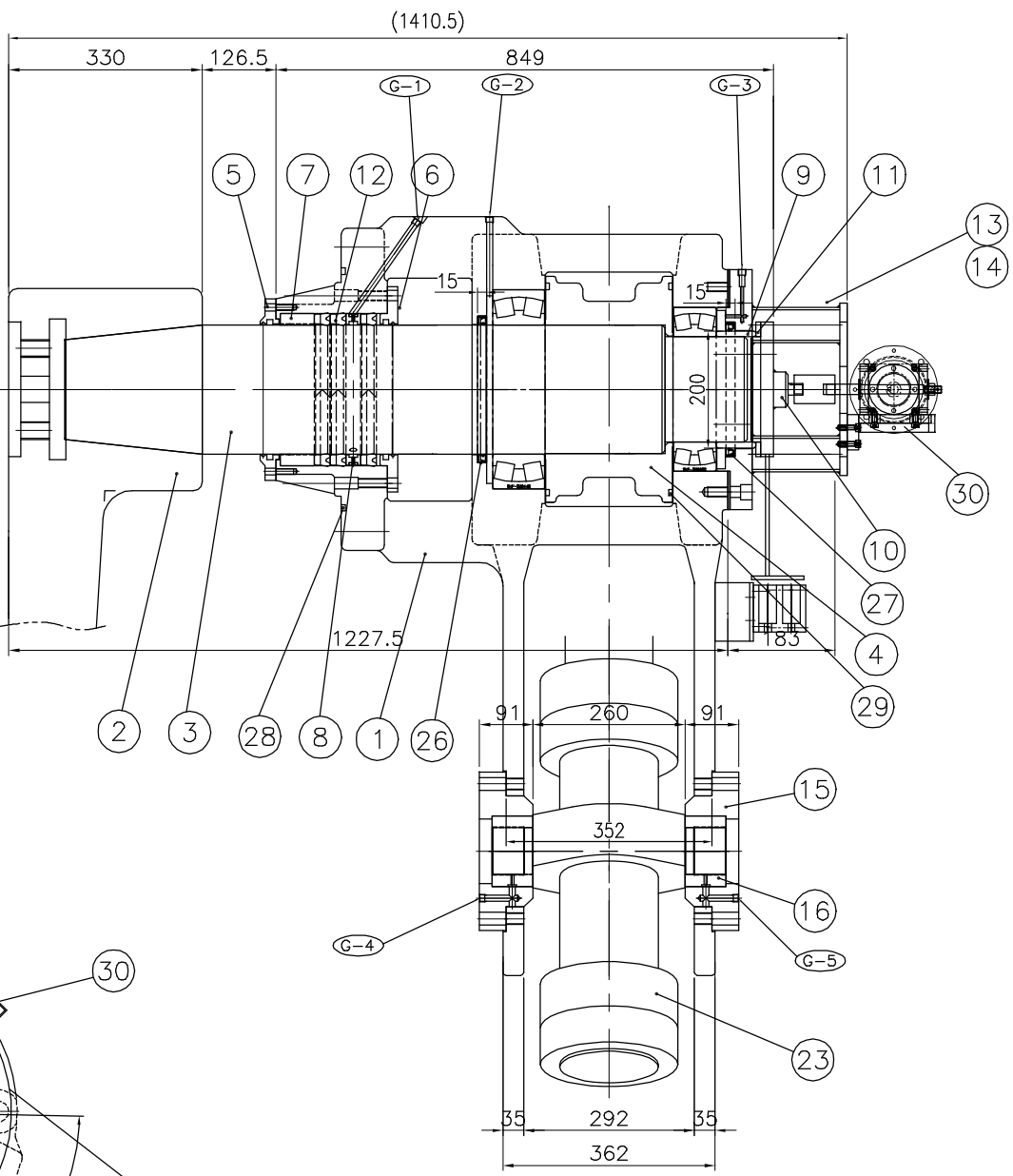
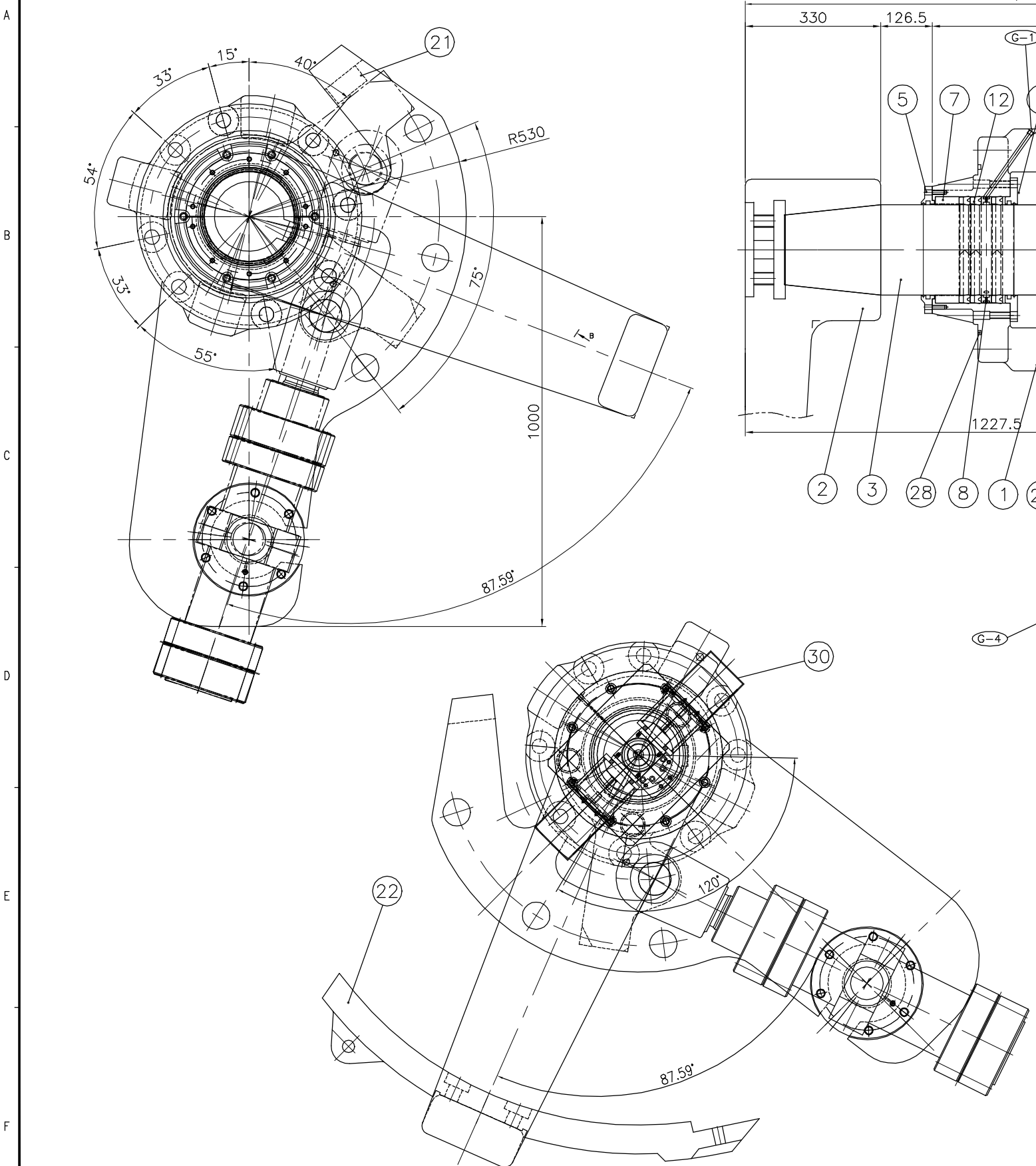

NO.	DESCRIPTION	MAT*(KS)	QUANTITY		WEIGHT(KG)		REMARK'S
			UNIT	TOTAL	PERUNIT	TOTAL	
	MATERIAL CONTROL GATE		SET	1	-	2920.2	
1	VALVE BODY	SC49	EA	1	-	980	
2	CARRING ARM	SC49	EA	1	-	490	
3	LINK SHAFT	SM45C	EA	1	-	335	
4	LINK ARM	SC49	EA	1	-	195	
5	FRONT COVER	SM45C	EA	1	-	17.5	
6	REAR COVER	SM45C	EA	1	-	18.4	
7	FRONT BUSHING	BC3	EA	1	-	24.2	
8	PISTON RING	SS275	EA	1	-	3.5	
9	BEARING COVER	SS275	EA	1	-	3.1	
10	END CAP	SS275	EA	1	-	12.7	
11	CAP SPACE	SM45C	EA	1	-	1.4	
12	PACKING	NEOPRENE	EA	3	-	-	
13	BEARING COVER	SS275	EA	1	-	66.7	
14	GASKET	NON.ABS	EA	1	-	-	
15	BUSH HOUSING	SS275	EA	1	-	48.4	
16	CYLINDER BUSH	BC3	EA	2	4.1	8.2	
17	LINK COLLAR	SM45C	EA	2	0.4	0.8	
18	LINK SPACER	SM45C	EA	1	0.4	0.8	
19	CYLINDER PIN	SM45C	EA	1	-	9	
20	STOPPER PIN	SM45C	EA	1	-	12.3	
21	STOPPER BLOCK	SC49	EA	1	-	7.2	
22	GATE	SC49	EA	1	-	491	
23	HYDRAULIC CYLINDER	PUR.	SET	1	-	195	φ125x371st
24	ROLLER BEARING	PUR.	EA	1	-	-	#23044C
25	ROLLER BEARING	PUR.	EA	1	-	-	#23036C
26	OIL SEAL	N.B.R	EA	1	-	-	SA-220
27	OIL SEAL	N.B.R	EA	1	-	-	S-200
28	O-RING	N.B.R	EA	1	-	-	P400
29	O-RING	N.B.R	EA	2	-	-	P340
30	ENCODER	-	EA	1	-	-	-

TOTAL WEIGHT : 2,920.2(Kg)X2SET=5,840.4(Kg)

Item Name: MCG
Model No.: FSP-FT-MC01-001

SCALE	1/6	PROJECTION	☐
SIZE	A3	DIMENSION	mm
TITLE	HOPPER SYSTEM GAS SEAL HOPPER ASSEMBLY OF MATERIAL CONTROL GATE		
DATE	24.11.20	FOR REFERENCE	S.C.PARK - O.R.SONG K.S.SONG
NO.	DATE	REVISION & DESCRIPTION	DRAWN CHECKED REVIEWED APPROVED
		FINE (주) 파인 FINE INC	
DRW. NO.	24.11.20	CHK. NO.	24.11.20
REV. NO.	-	REV. NO.	-